

Sto reStore Smooth recoat

Detail No.: 72.01

Date: December 2010

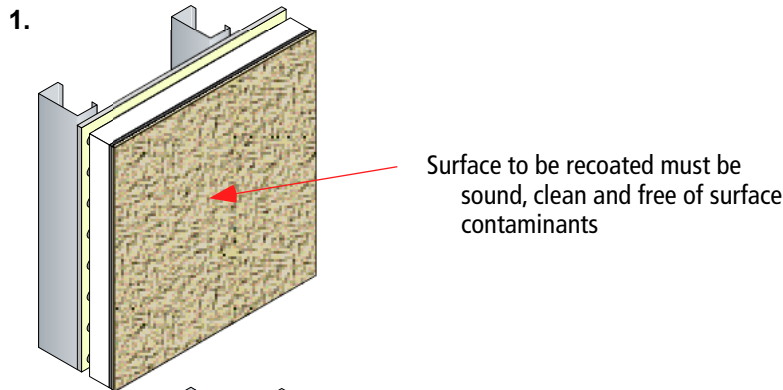

1. Inspect surface to ensure it is sound and clean.

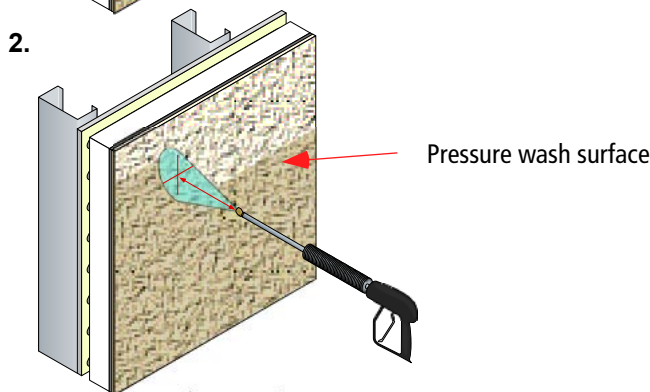

2. Follow the directions for cleaning in StoTherm® EIFS Reference Guide: Repair and Maintenance, Cleaning EIFS 1.01.

Caution: When pressure washing surface, use pressure below 500 psi (3.4 MPa) and keep the nozzle several feet away from the surface.

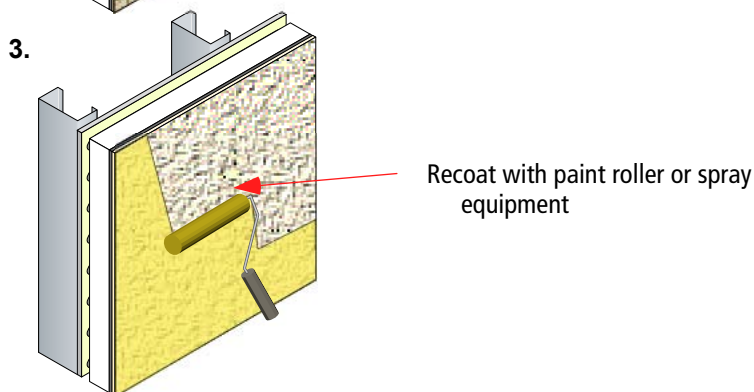

3. When the surface is dry and clean, recoat using appropriate paint roller or spray equipment. Refer to StoTherm® EIFS Reference Guide: Repair and Maintenance, Recoating EIFS 1.02.

Sto Corp.
3800 Camp Creek Parkway
Building 1400, Suite 120
Atlanta, GA 30331
Phone 404-346-3666
Toll Free 888-786-3437
Fax 404-346-3119
www.stocorp.com

Attention

Sto products are intended for use by qualified professional contractors, not consumers, as a component of a larger construction assembly as specified by a qualified design professional, general contractor or builder. They should be installed in accordance with those specifications and Sto's instructions. Sto Corp. disclaims all, and assumes no, liability for on-site inspections, for its products applied improperly, or by unqualified persons or entities, or as part of an improperly designed or constructed building, for the nonperformance of adjacent building components or assemblies, or for other construction activities beyond Sto's control. Improper use of Sto products or use as part of an improperly designed or constructed larger assembly or building may result in serious damage to Sto products, and to the structure of the building or its components. **STO CORP. DISCLAIMS ALL WARRANTIES EXPRESS OR IMPLIED EXCEPT FOR EXPLICIT LIMITED WRITTEN WARRANTIES ISSUED TO AND ACCEPTED BY BUILDING OWNERS IN ACCORDANCE WITH STO'S WARRANTY PROGRAMS WHICH ARE SUBJECT TO CHANGE FROM TIME TO TIME.** For the fullest, most current information on proper application, clean-up, mixing and other specifications and warranties, cautions and disclaimers, please refer to the Sto Corp. website, www.stocorp.com.