

Sto reStore

Sign repair: non wood substrates

Detail No.: 74.82a

Date: December 2010

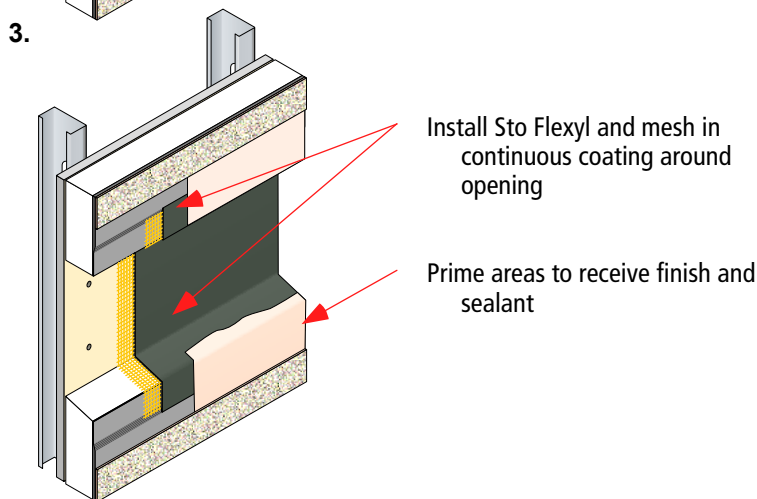
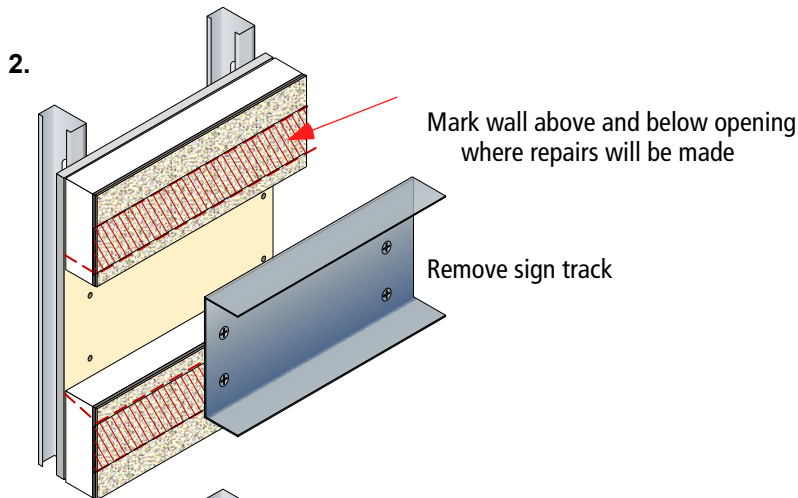
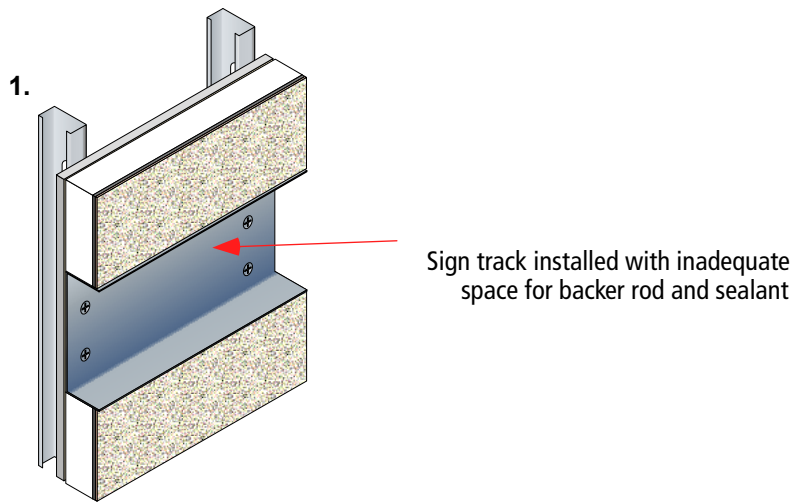

1. Procedure illustrates repairs to sign track set into an EIFS cladding with inadequate protection against water penetration through or around the perimeter of the sign. Gypsum based sheathing is installed behind the signage.

2. Remove the sign track and mark the EIFS 6" (150 mm) above and below the opening. Cut the EIFS back 3/4" (20 mm) on the top edge and the bottom edge. Cut the bottom edge on a slope.

Prepare the base coat and finish above and below the opening as outlined in Sto reStore Detail 74.06 except that insulation will not be placed into the opening.

Inspect the substrate behind the sign channel for damage. Modify the scope of work to include repair to the substrate if necessary.

3. Install Sto Flexyl and Sto Mesh overlapping the existing base coat and mesh 2.5" (65 mm) as out-

lined in Sto reStore Detail 74.06 . Wrap the Sto Flexyl and mesh from the face of the upper and lower insulation, over the new cut edge, and over the gypsum based sheathing. Allow the Sto Flexyl to cure for a minimum of 24 hours.

Coat the dry Sto Flexyl where finish and sealant will be installed with Sto Primer.

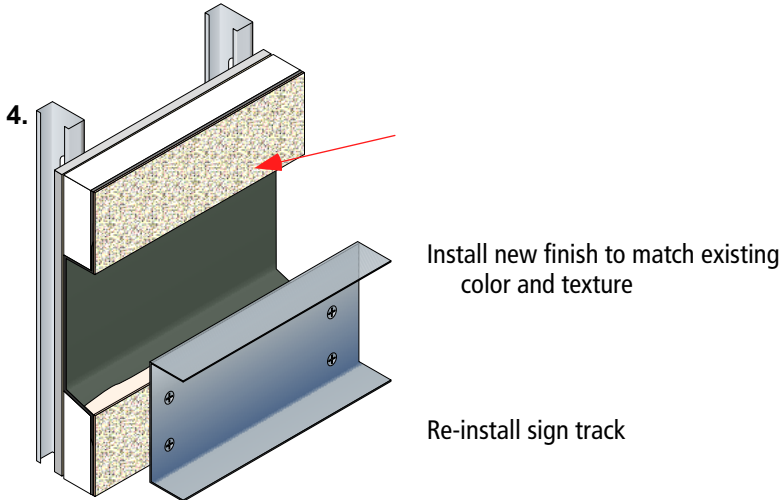

4. Re-mask the area around the edge of the finish. Install new finish within area protected by the masking tape. Immediately remove the masking tape and blend the new finish into the existing with a brush or other appropriate tool.

Protect the new finish until dry.

Depending on the age of the original finish the repair may remain visible as a repair. Texture may be slightly different from the original and the color may differ slightly. Over time the repair will 'weather in' and be less noticeable.

IF a more uniform finish is required refer to ReStore Detail 72.01 Recoat with Smooth Coating or 72.02 Rebase with Texture Coating for alternate finishing procedures.

Re-install sign track. Set new fasteners and electrical connections into sealant to prevent water penetration into the interior.

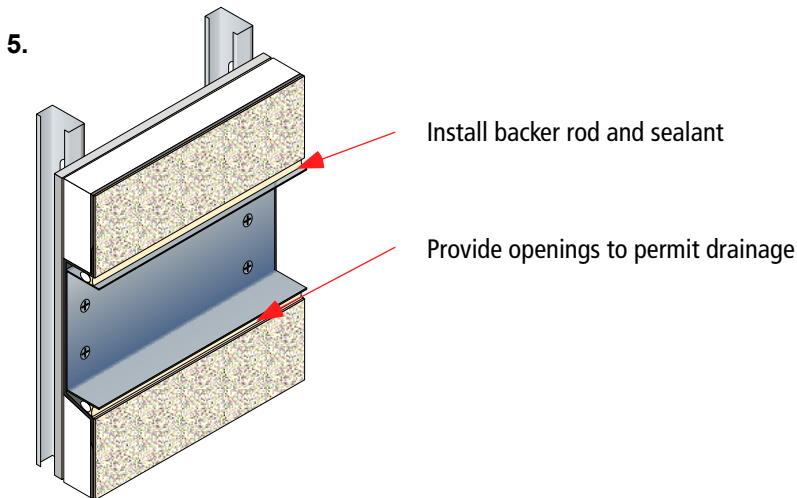

5. Install closed cell backer rod and neutral-cure silicone sealant in the space between the sign track and the Sto Primer and Flexyl. Check with sealant manufacturer for appropriate sealant and sealant primer, if required. Leave gaps in the sealant to allow water that penetrates the sign or sign track to drain.

Sto Corp.
 3800 Camp Creek Parkway
 Building 1400, Suite 120
 Atlanta, GA 30331
 Phone 404-346-3666
 Toll Free 888-786-3437
 Fax 404-346-3119
www.stocorp.com

Attention

Sto products are intended for use by qualified professional contractors, not consumers, as a component of a larger construction assembly as specified by a qualified design professional, general contractor or builder. They should be installed in accordance with those specifications and Sto's instructions. Sto Corp. disclaims all, and assumes no, liability for on-site inspections, for its products applied improperly, or by unqualified persons or entities, or as part of an improperly designed or constructed building, for the nonperformance of adjacent building components or assemblies, or for other construction activities beyond Sto's control. Improper use of Sto products or use as part of an improperly designed or constructed larger assembly or building may result in serious damage to Sto products, and to the structure of the building or its components. **STO CORP DISCLAIMS ALL WARRANTIES EXPRESS OR IMPLIED EXCEPT FOR EXPLICIT LIMITED WRITTEN WARRANTIES ISSUED TO AND ACCEPTED BY BUILDING OWNERS IN ACCORDANCE WITH STO'S WARRANTY PROGRAMS WHICH ARE SUBJECT TO**

CHANGE FROM TIME TO TIME. For the fullest, most current information on proper application, clean-up, mixing and other specifications and warranties, cautions and disclaimers, please refer to the Sto Corp. website, www.stocorp.com.